

BATTLE McCARTHY©

Consulting Engineers & Landscape Architects

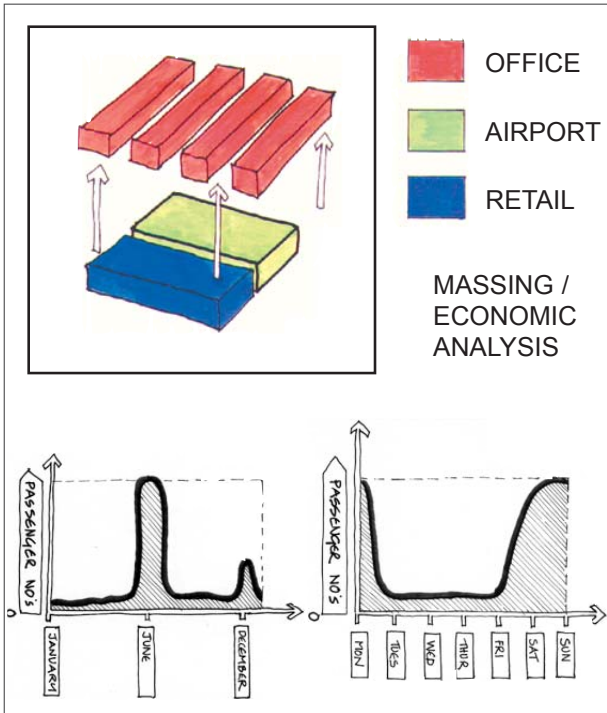

PROJECT:

Jersey Airport, Economic Funding Strategy

CLIENT:

Jersey Energy & Environmental Control

ARCHITECTS:

N/A

BM SERVICES:

Multi-disciplinary engineering

VALUE:

Classified

DESIGN BRIEF

To develop a design approach for the expansion of the existing terminal. In response to JE ECS economic strategy Battle McCarthy were asked to generate a discussion with the view to a possible economic feasibility study for the airport.

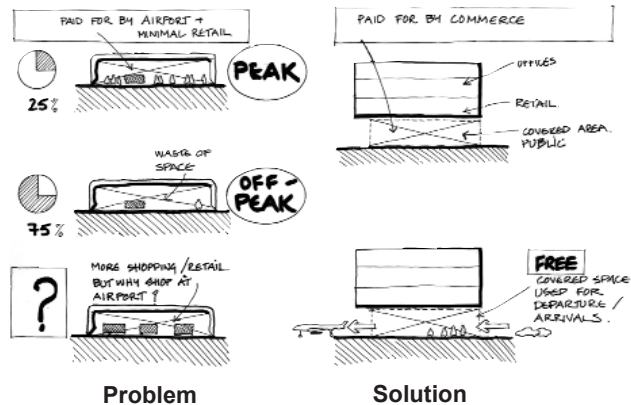
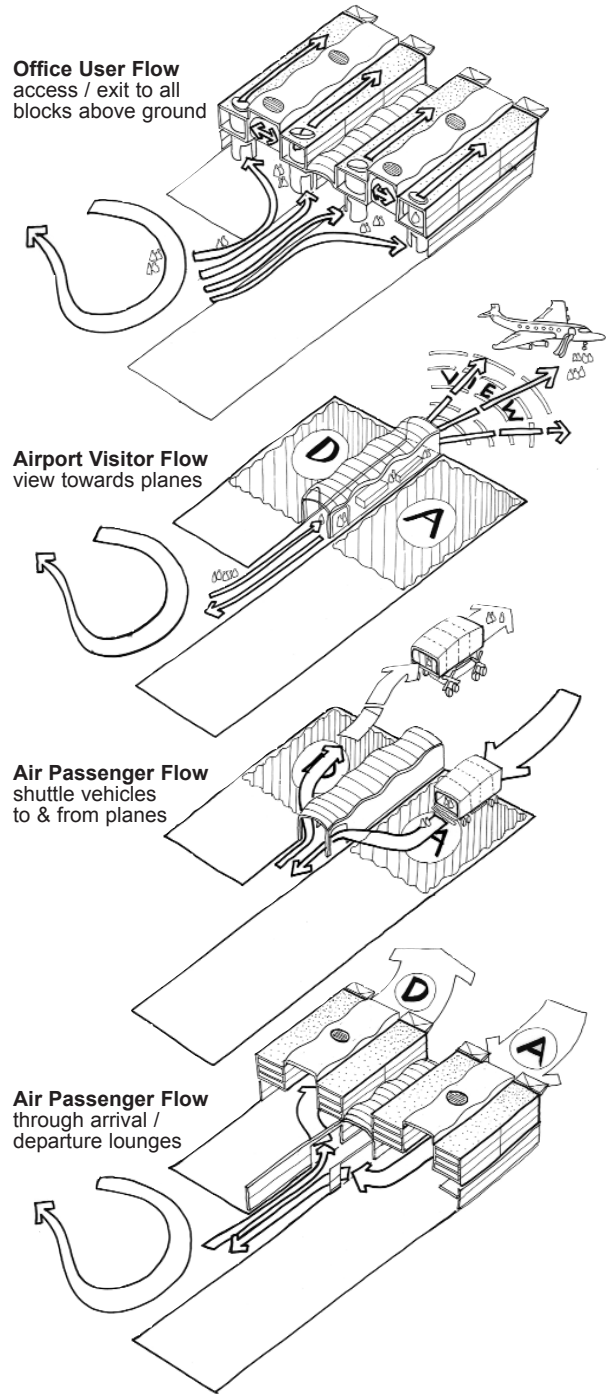

London UK Office
 T: +44 (0)20 7440 8282
 F: +44 (0)20 7440 8292
 E: admin@battlemccarthy.com
 www.battlemccarthy.com